

SunSDR2Pro - Test



The SunSDR2Pro is a direct-sampling, network-ready 16-bit SDR transceiver for the frequency ranges 9kHz to 65MHz (KW) and 96-148MHz (2m). The transceiver is connected via its Ethernet interface to a PC (Win 7 to 10) or integrated into the home network via a switch/router. To start the transceiver you need the software "Expert SDR2", whose current version of Expert Electronics can be downloaded at <https://eesdr.com>. In my tests I used the software "ExpertSDR2 v.1.3.0 Beta1_SunSDR2_PRO". The manufacturer supplies several operating instructions in different languages.

Installation and startup

The SunSDR2 can be integrated into a home network via its Ethernet interface, much like a network printer or mass storage, and has a static IP address of 192.168.16.200. There are two ways to operate the SunSDRPro: Either only from a single PC, or via all PCs / notebooks in the home network (**Fig. 1**).

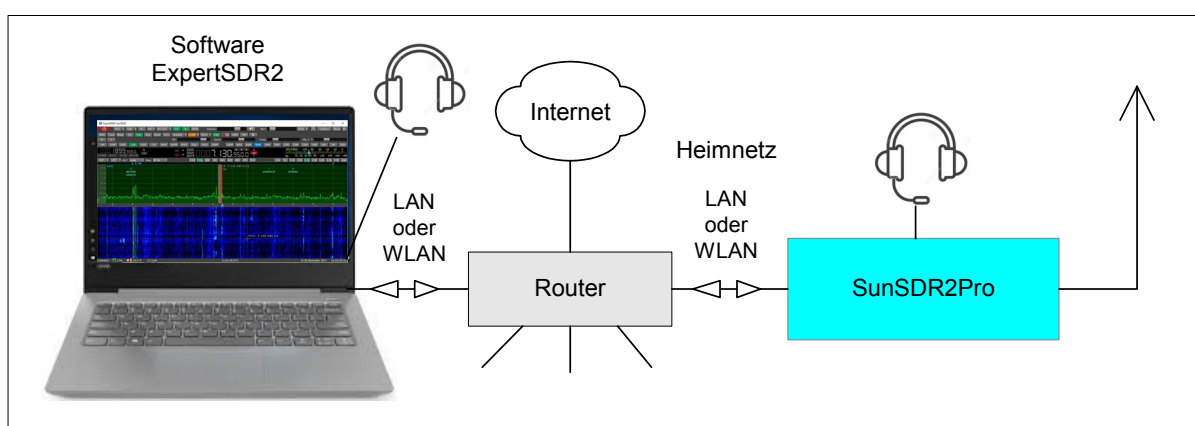

Figure 1: Operation of the SunSDR2Pro in the home network

First, the SunSDR2Pro must be recognized by the PC. To do this, connect the transceiver to a PC (Win7-10) via the supplied LAN cable and set the IP address of the PC under Control Panel -> Network -> Change Adapter Settings -> LAN Connection -> Properties -> Internet Protocol to e.g. 192.168.16.50 (50 or 1 ... 199) (**Fig. 2, left**). Then the SunSDR2Pro is recognized by the PC and can be started. The installation of the transceiver with direct connection to a single PC is now complete.

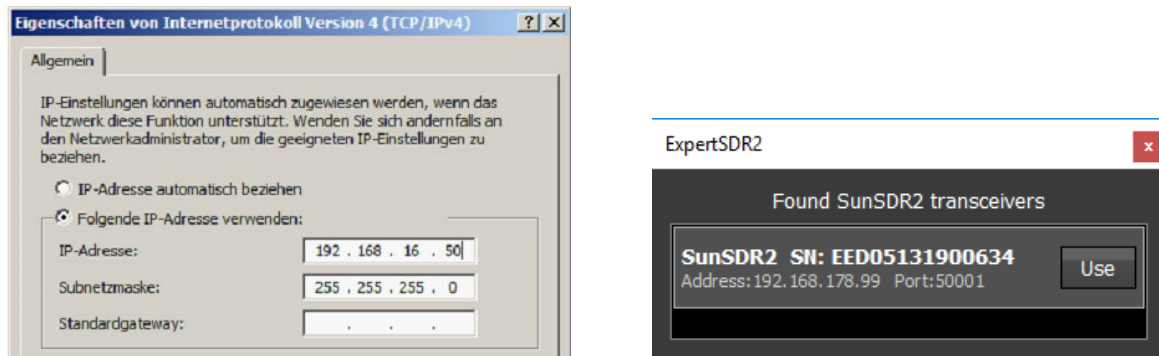

Figure 2: Setting the IP address on the PC SunSDR2Pro in the network

However, if the transceiver should be enabled for the entire home network (that will probably be the case most of the time) the address of the SunSDR2Pro must be set to a free network IP address. To find a free IP address in the home network, I just open the menu of the router and look for which address is still free, for me it was for example 192.168.178.99. Then enter the desired IP address in the Menu -> Options -> Expert under SDR Address and save it under "Set IP Address". Turn off the transceiver, disconnect the LAN cable from the PC and connect to the Router instead. After the transceiver is switched on again, the transceiver then automatically connects to the home network via the previously stored IP address. To check this, open Options -> Discover -> Found SDR2 Transceiver and the new IP address of the SunSDR2Pro is displayed (**Fig. 2, right**).

Afterwards, the SunSDR2Pro can be started and used by all PCs / Notebooks in the home network and the "Remote Control" has no limits.

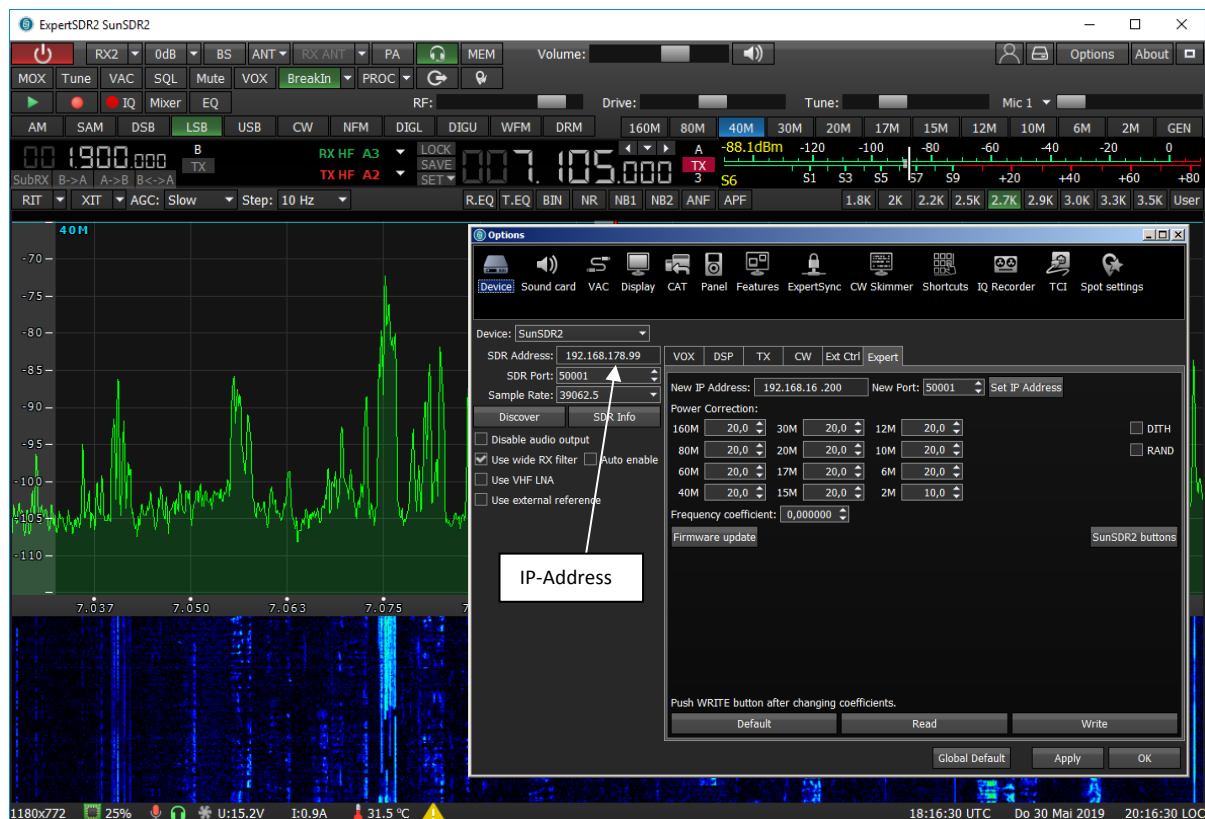

Figure 3: SunSDR2Pro screen and the menu -> Options

Measurements on the receiver

S-meter accuracy

First, the accuracy of the S-meter is checked. For this purpose, an RF signal at 14.2 MHz with levels from -122 to -13 dBm is fed (IN) into the receiver and compared with the dBm display of the S-meter.

Settings: Frequenz 14,2MHz, CW 500Hz, Wide RX-Filter off, Dith off, Rand off, Preamplicator off

| | S1 | S2 | S3 | S4 | S5 | S6 | S7 | S8 | S9 | S9+10 | S9+20 | S9+30 | S9+40 | S9+50 | S9+60 |
|---------------|------|------|------|------|-----|-----|-----|-----|-----|-------|-------|-------|-------|-------|-------|
| IN dBm | -121 | -115 | -109 | -103 | -97 | -91 | -85 | -79 | -73 | -63 | -53 | -43 | -33 | -23 | -13 |
| S dBm | -122 | -115 | -109 | -103 | -96 | -90 | -84 | -78 | -73 | -62.5 | -52.6 | -42.3 | -33 | -23 | -12,5 |

Table 1: S meter display and dBm

The level meter works very well even down to S1, the max. Error is about 1dB. With this accuracy, the SunSDR2Pro can also be used as a "RF level meter".

Sensitivity (MDS, Minimum Decernable Signal) and Noise (NF, Noise Figure)

To measure the sensitivity, we tune the receiver to the frequency of a tunable signal generator and reduce its level until the demodulated CW signal (600Hz) is only 3 dB larger than the noise floor of the receiver. The display device used is a broadband AC voltmeter on the NF output or the S meter.

Table 2 shows the detected sensitivity, with and without + 10dB preamplifier.

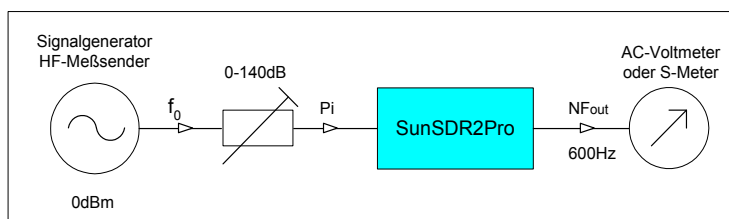

Figure 4: Test setup to determine the sensitivity

Settings: B=500Hz CW, AGC on, Dither & Random off, Wideband RX-Filter on

| Preamp | 3,6MHz | 7,1MHz | 14,1MHz | 21,3MHz | 28,1MHz | 50,1MHz |
|------------|--------|--------|---------|---------|---------|---------|
| on | -134 | -134 | -134 | -133 | -133 | -132 |
| off | -125 | -126 | -126 | -126 | -124 | -123 |

Table 2: Sensitivity (MDS) in dBm

With a noise limit of -174dBm / Hz, the noise figure is calculated to

$$\text{Noise figure (NF)} = \text{MDS} - \text{Noise limit} - 10\log B = \text{MDS} + 147\text{dB}$$

| Preamp | 3,6MHz | 7,1MHz | 14,1MHz | 21,3MHz | 28,1MHz | 50,1MHz |
|------------|--------|--------|---------|---------|---------|---------|
| on | 13dB | 13dB | 13dB | 14dB | 13dB | 15dB |
| off | 22dB | 21dB | 21dB | 21dB | 23dB | 24dB |

Table 3: Noise figure over frequency

Note: If bandpass filters are placed in front of the receiver instead of the wide band RX filter (65MHz TP filter), the noise level increases by about 3dB. If the Dithering function is switched on, the noise level increases again by 5 ... 8dB.

Reciprocal Mixing Dynamic Range (RMDR) and Side Band Noise (SBN)

When mixing an RF signal with an oscillator, the oscillator side band noise also transmits to the resulting IF signal. This undesirable effect is called "Reciprocal Mixing Noise". Small signals near larger signals can be covered by the sideband noise of the oscillator. The receiver experiences a loss of sensitivity or dynamics (desensitization), which is referred to as Reciprocal Mixing Dynamic Range, RMDR. This problem is mainly known from analogue receivers (1). Modern SDRs work with very low-noise, crystal-controlled clock oscillators and in contrast to analog receivers, the phase noise remains the same even at high frequencies. For RMDR measurement, the receiver is adjusted in frequency intervals of 0.5 to 5 kHz to a low-noise reference signal and the signal level (Pi) is increased until the background noise of the receiver at the audio output increases by 3dB. As a reference oscillator, I use an Ultra Low Phase Noise 10MHz OCXO from KVG with an SBN of -168dBm / Hz at 1 kHz spacing. (Fig. 5 and 6).



Bild 5: Messaufbau zur Ermittlung von RMDR und SBN

The RMDR of the receiver is calculated to

$$RMDR = P_i - MDS$$

with P_i = input level in dBm, $MDS = -124dBm / 100Hz$ bandwidth

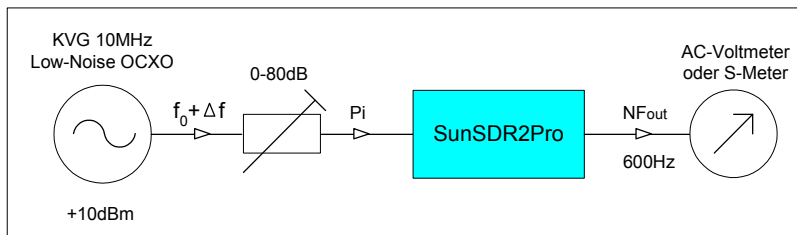
and the sideband noise (SBN) too

$$SBN = - RMDR - 10\log B$$

with $10\log B = 10\log 100Hz = 20dB$

Note: The bigger the RMDR and the smaller the SBN, the better for the receiver.

Settings: $f_e = 10MHz$, CW, $B = 100Hz$, Gain on, Dither on, Wide RX-Filter off, Resolution 100Hz, Averaging num 30, Update period, 50mS, FFT size 8193, Sample rate 39062,5

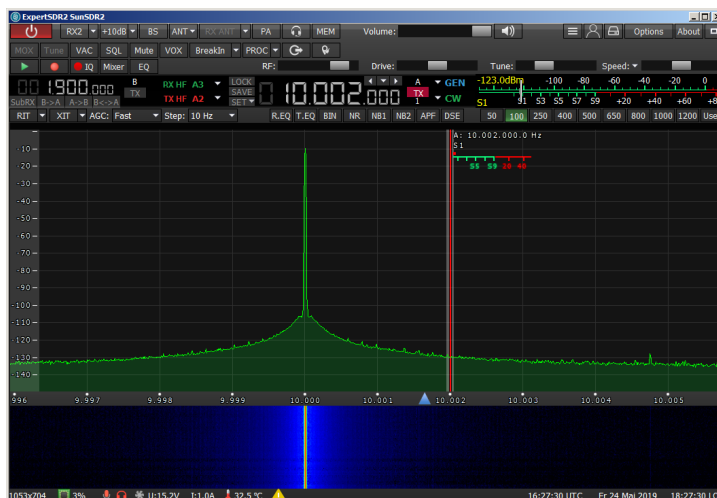

Figure 6: Measurement of sideband noise

Ultra Low Phase-Noise 10MHz OXO

| | | | |
|-------------|--------|---------|------------|
| Delta f kHz | Pi dBm | RMDR dB | SBN dBc/Hz |
|-------------|--------|---------|------------|

| | | | |
|-----|-----|-------|------|
| 0,5 | -32 | 92 | -102 |
| 1 | -15 | 109 | -129 |
| 2 | -7 | 117 | -137 |
| 3 | -6 | 118 | -138 |
| 4 | -5 | 119 | -139 |
| 5 | -4 | Clip! | |

Table 4: RMDR and SBN (Phase Noise) as a function of Pi

In an offset of 2 kHz to a CW signal of -7dBm (S9 + 65dB) the receiver's RMDR (dynamics) is 117dB. Without the CW signal, the dynamics are: MDS - Clippinglevel = 124dBm - (-4dBm) = 120dB.

Note: In an RMDR measurement, make sure that the generated sideband noise of the reference oscillator used at all offsets must be smaller than that of the tested oscillator, otherwise you measure the SBN of the reference oscillator and not that of the oscillator and the results will be wrong (too small) (1). Reciprocal mixing just happens in both directions.

Blocking Dynamic Range (BDR)

The Blocking Dynamic Range states how well a receiver can process very small signals in the vicinity of very large signals without losing sensitivity. The maximum BDR of a receiver is reached when a small signal in distance of 2 kHz beside a large signal lose amplitude by 1dB (desensitization) (2). In direct-sampling receivers, a BDR measurement is in principle no longer relevant, because an ADC does not apply compression to small signals when converting large signals. An ADC knows neither a "1dB compression" nor a "blocking dynamic range", but a limitation (saturation). Nevertheless, many manufacturers like to include the BDR of their receivers in the data sheet, because they usually achieve very high dB values.

The result of a BDR measurement on the SunSDR2Pro in the 40m band is shown in **Figure 7**. Even with a signal strength of 0dBm (224mV, S9 + 73dB), the level of a small -100dBm signal at a distance of only 2 kHz remains completely unimpressed. Calculating from this knowledge the BDR reaches a value of

BDR = Clipping Level - MDS => 0dBm - (-120dBm) = > 120dB

Settings: CW, B=500Hz, Gain off, Wide RX-Filter on, Dither & Random on

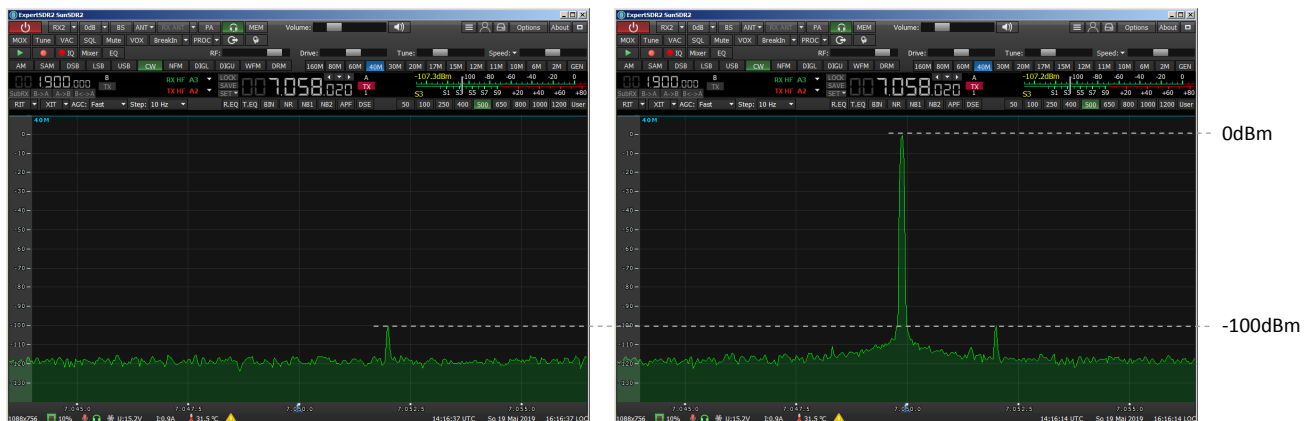

Figure 7: An A/D converter does not know a "blocking dynamic range" but a saturation

IMD3, 3rd order intermodulation

To test the intermodulation, we load the input of the receiver with two equally large HF signals, in

the example at $f_1 = 7050 \text{ kHz}$ and $f_2 = 7052 \text{ kHz}$ and increase their level - starting from $P_i = 2x-70\text{dBm}$ - up to the limit (saturation) of the receiver **(3)**.

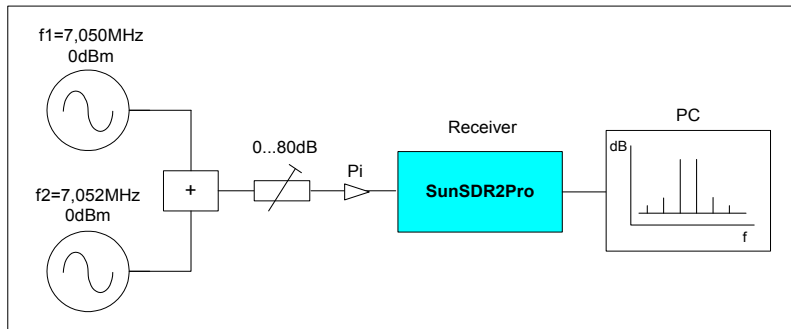

Figure 8: Receiver IMD3 measurement

HF 2-tone generator

In contrast to analogue receivers, the IMD3 interfering products do not increase at triple speed, but remain close to the background noise level and increase only at limitation (saturation). The largest, distortion-free dynamic range is only reached shortly before the ADC is limited. **Figure 9** shows the measured curves of the IMD3 products, with different basic settings of the receiver, with Preamp on/off and Wide Band Filter (WBF) (65MHz TP filter) on/off.

Settings: $f_1=7,050\text{MHz}$, $f_2=7,052\text{MHz}$, CW, 500Hz, AGC off, Dith & Rand on

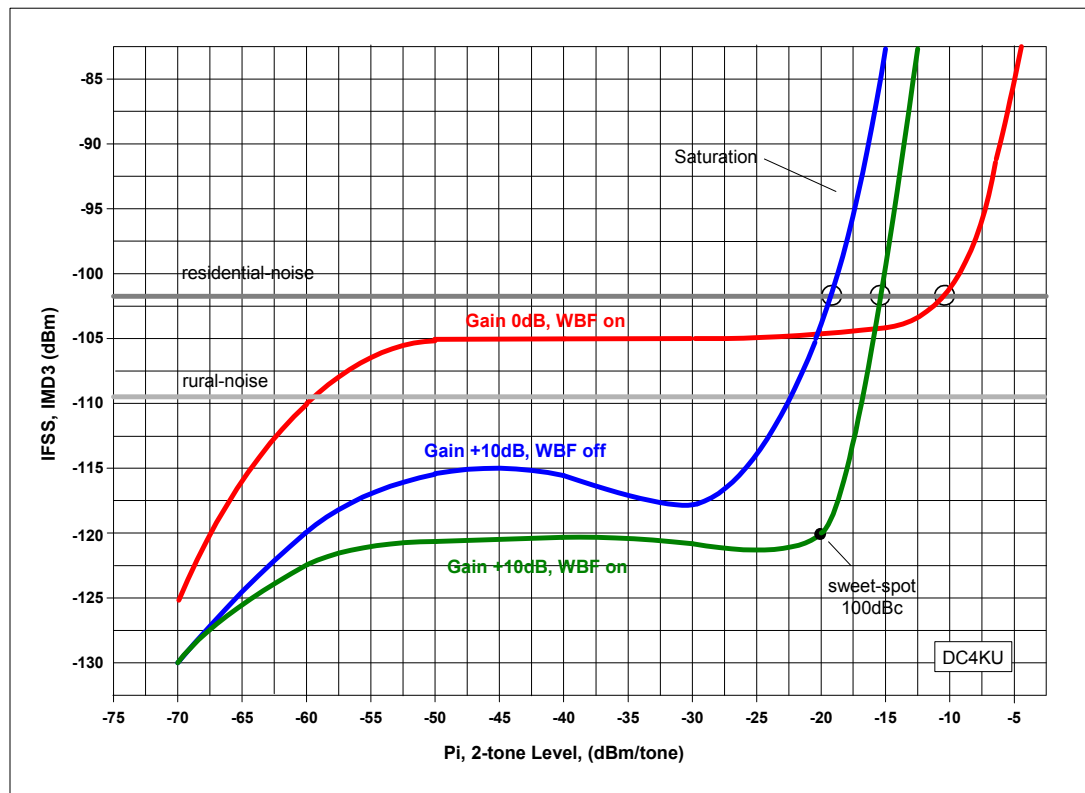

Figure 9: IMD3

The green trace, with + 10dB gain and WBF on, shows the largest, distortion-free dynamic. At an input level of $2x-20\text{dBm}$, the resulting IMD3 products are suppressed by 120dB, resulting in a DR3 (Dynamic Range 3rd Order) of 100dB. At slightly larger signal the ADC then gets into saturation. The other curves show the behavior of the receiver when the gain and WBF are switched on and off. If the band pass filters are switched on (blue curve), the receiver gets into limitation slightly earlier. This effect is evidently caused by insufficient IMD3 strength (large signal strength) of the bandpass

filters used, here the developers are again required. Without preamplification (red curve) and switched off bandpass filters, the receiver will only saturate at 2x-10dBm (S9 + 63dB).

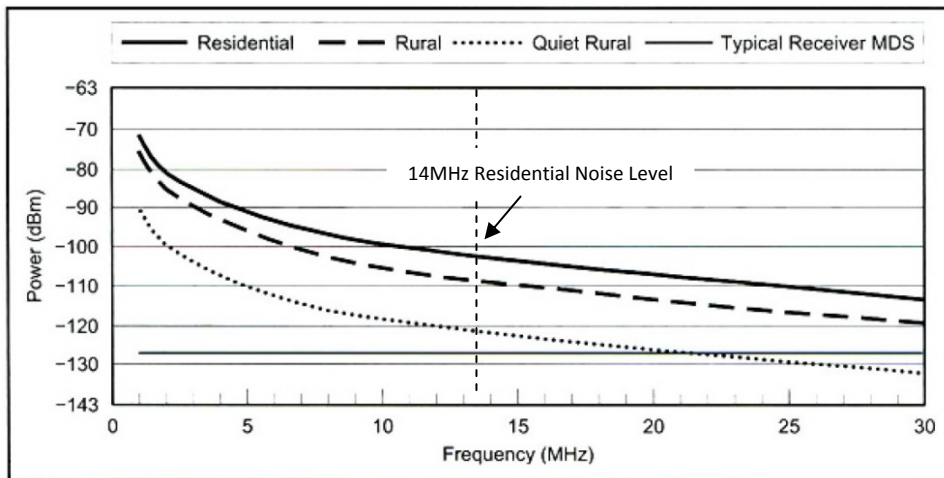

Figure 10: Type. External noise in urban areas (Residential, Urban) and in rural residential areas (Rural), (Man-Made Noise in 500Hz bandwidth, from Rec. ITU-R P.372-7, Radio Noise, ARRL Handbook)

It is important that the course of all traces until saturation is below the Residential Noise or Rural Noise line (Figure 10) (4, 5). If this is achieved, the IMD interfering products are no longer audible / detectable when connecting an antenna.

What's about the "IP3"? As many OMs would like it, an IP3 (third-order intercept point) cannot be determined. If you tried anyway, there would be a different IP3 value for each input level. With direct-sampling SDRs there is no IP3 because there is no mathematical relationship for this.

Dither & Random



Bild 11: Zweitton-Signal mit 2x-20dBm am Eingang des Receivers, mit Dith & Rand (links) und ohne (rechts). Mit Dith & Rand beträgt die verzerrungsfreie Dynamik 100dBc, die IMD3-Signale verschwinden im Rauschen.

Obviously an ADC feels "more comfortable" at a high modulation than at a lower one. This circumstance is exploited, by optionally supplying a noise signal to the input of the ADC (6). This function is called Dither, ICOM calls it "IP+" By enabling dithering and output randomization in the ADC, the linearity and IMD dynamics of the SDR can be improved. As an example, Figure 11 shows a 2-tone signal with and without dithering. When Dither is turned on, the IM3 products go back almost 20dB. At the same time, the background noise increases by almost 10dB. With the SunSDR2Pro this function can be permanently switched on or off under Options -> Device -> Expert -> DITH, RAND on

/ off -> Write. In normal radio operation, dithering is not required because the noise floor of the antenna is already sufficient as an external signal.

Note on the 2-tone generator: For error-free IMD3 measurements, the generated IMD3 distance of the 2-tone generator itself must be greater than 100dBc (see **Figure 11**), otherwise you run the risk of measuring the IMD3 of the 2-tone generator and not the object of measurement, here the receiver (3).

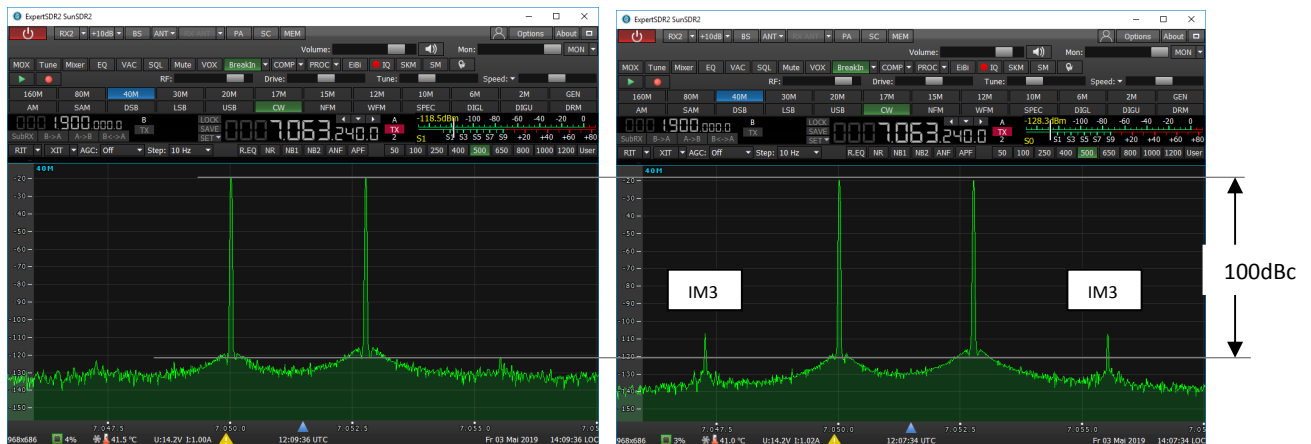
IMD2, Intermodulation 2nd order

A second-order intermodulation measurement is expedient, because it controls the suppression of unwanted sum signals ($f_1 + f_2$). In the example, I use signals at 6.1MHz and 8.1MHz and measure the sum signal (IMD2) in the 20m band at 14.2MHz. In this measurement, the level (Pi) of both signals is increased until the IMD2 signal with +3dB becomes audible from the noise floor, then it has reached the sensitivity (MDS). The IMD2-free dynamic range (DR2) of the receiver is then

DR2 = Pi - MDS, (DR2 = Dynamic Range 2nd Order)

Settings: $f_1=6,1\text{MHz}$, $f_2=8,1\text{MHz}$, $f_e=14,2\text{MHz}$, CW, B=500Hz, RX-Filter off, Gain off, Random on

| Gain | MDS dBm | Pi dBm | DR2 dB |
|-------|---------|--------|--------|
| +10dB | -130 | -20 | 110 |
| 0dB | -122 | -20 | 102 |

Table 5: DR2 measurement at $f_1 + f_2 = 14.2\text{MHz}$

Note: The IMD2 distance generated by the HF 2-tone generator itself must be greater than 100 dB, otherwise the results will be incorrect (too small). Under circumstances, a LP filter at the output of the generators can help.

Noise Power Ratio (NPR)

The NPR (Noise Power Ratio) measurement is used for the detection of the high signal strength of a receiver (7, 8, 9). The input of the receiver is no longer controlled with CW signals, but with a white noise band of constant power. **Fig. 12** shows the test setup, consisting of noise generator, notch filter (notch filter), bandpass filter and attenuator and **Figure 13** shows the spectrum at the output of the measuring station.

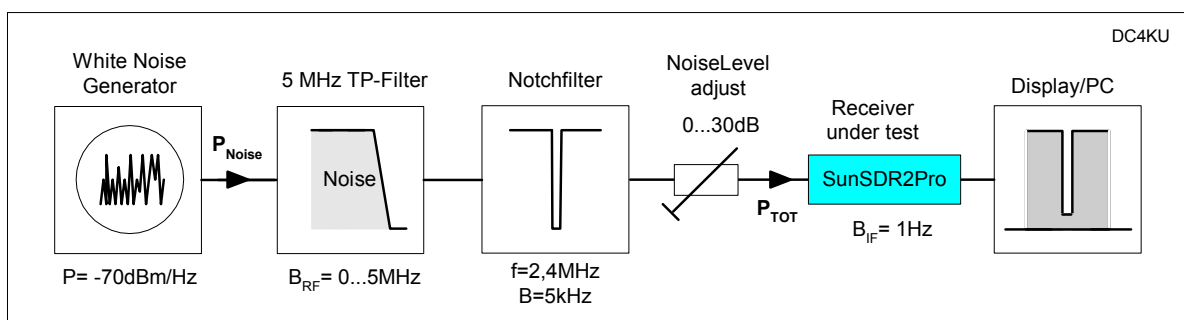

Figure 12: NPR test setup

The notch filter has the task of eliminating the noise at one point in the frequency band, in the example at $f_e = 2,4\text{MHz}$. The receiver is tuned to the center of the notch filter and the noise signal is increased until the ADC saturates. This limitation can be recognized by a sudden noise rise in the bottom of the notch filter. Then reduce the noise power by 1...3dB until no more rise can be detected in the base of the filter. At this point, the NPR of the receiver is reached and corresponds to

the difference of applied noise power (P_{TOT}) to the noise floor (MDS) in the base of the notch filter.

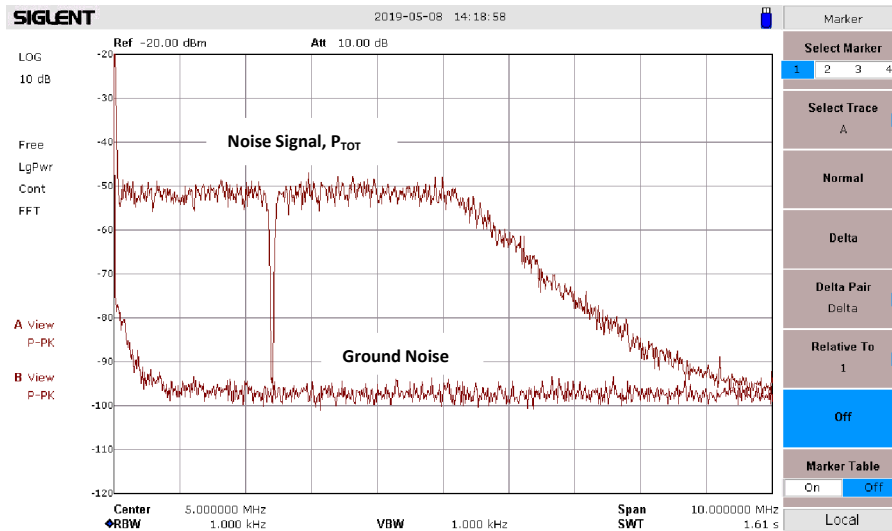

Figure 13: Spectrum at the input of the receiver. Noise signal up to 5MHz, except in the notch filter

The resulting NPR of the receiver can be read directly in the spectrum (**Figure 14**) it is 73dB with an input noise power of $P_{TOT} = -12\text{dBm} / 5\text{MHz}$. During the NPR-measurement the Wide RX-Filter (65MHz LP-Filter) is switched on so that no bandpass filter can limit the noise signal in front of the ADC.

Settings: Preamp off, NB off, Dither & Random off, Wide RX-Filter on, BW 1 kHz (B_{IF})



Bild 14: Noise Power Ratio = 73dB

The determined NPR values are shown in **Table 6**. With the preamplifier switched on, the NPR goes back a bit as expected. For comparison, the NPR of my **DDC SDR ColibriNANO**, with a resolution of 14Bit, is just **58dB (10)**.

| Preamp | P _{TOT} dBm | NPR dB |
|--------|----------------------|--------|
| 0dB | -12 | 73 |
| +10dB | -21 | 69 |

Tabelle 6: Noise Power Ratio of SunSDR2Pro

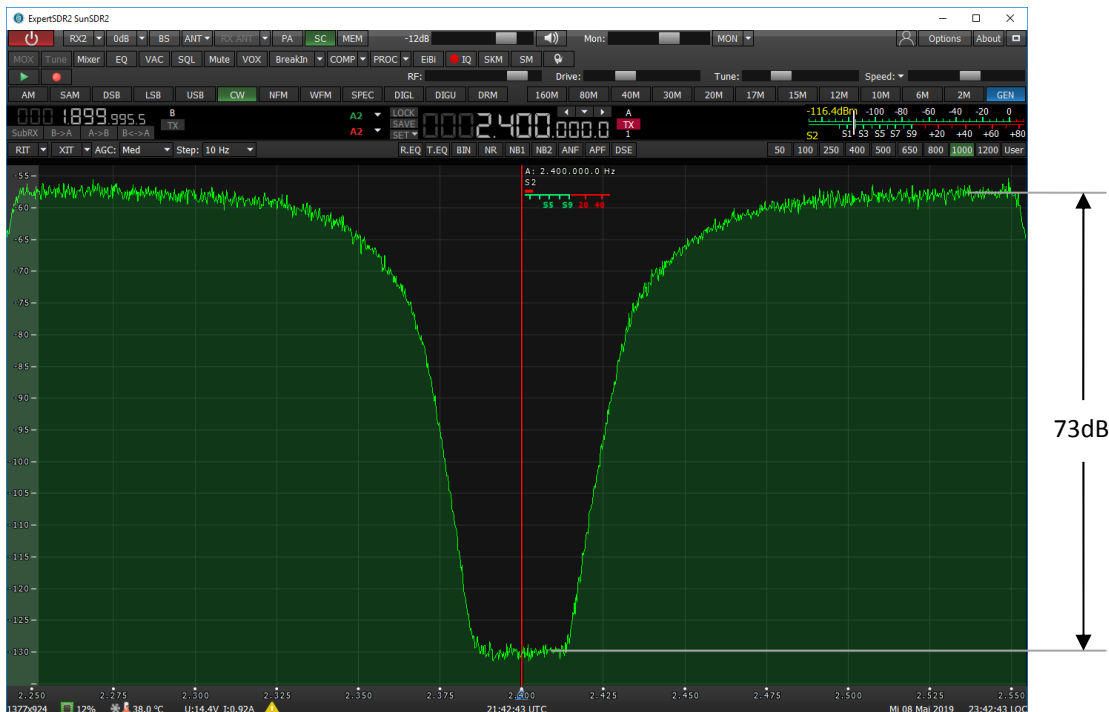
The theoretical NPR limit of a 16 bit A/D converter, driven by constant white noise across a bandwidth (BRF) of 5 MHz, is approximately 76 dB **(7)**.

Calculation of the NPR

$$\text{NPR} = \text{PTOT} - \text{BWR} - \text{MDS} = -12\text{dBm} - 10\log 5000\text{kHz} / 1\text{kHz} - (-122\text{dBm}) = 73\text{dB}$$

With

P_{TOT} = noise power (in the example referred to a bandwidth BRF of 5 MHz)

BWR (Bandwidth Ratio) = $10\log \text{BRF} / \text{BIF} = 10\log 5000\text{kHz} / 1\text{kHz} = 37\text{dB}$

B_{RF} = noise bandwidth of the generator (in the example 5 MHz)

B_{IF} = noise bandwidth of the receiver (in the example 1kHz)

MDS = -122dBm, noise floor of the receiver with Wide RX filter on

Note: To determine the high signal strength of a receiver, the NPR test seems more realistic to me than a test with only two CW signals. The injected noise signal has the same effect as many hundreds of equally sized CW signals. Functions such as Dither & Random have no influence here and can be switched off. Good receivers provide an NPR of about 70dB.

Wide RX filter

When the "Wide RX filter" is activated, the input of the receiver is limited by only a 65MHz LP-Filter instead of bandpass filters. The receiver then operates in broadband input from 0-65MHz, similar to a spectrum analyzer. This setting is chosen e.g. if you want to capture / see all received signals from 0-65MHz with the help of the "Bandscope" at the same time. **Fig. 15** shows the effect of the Wide RX Filter.

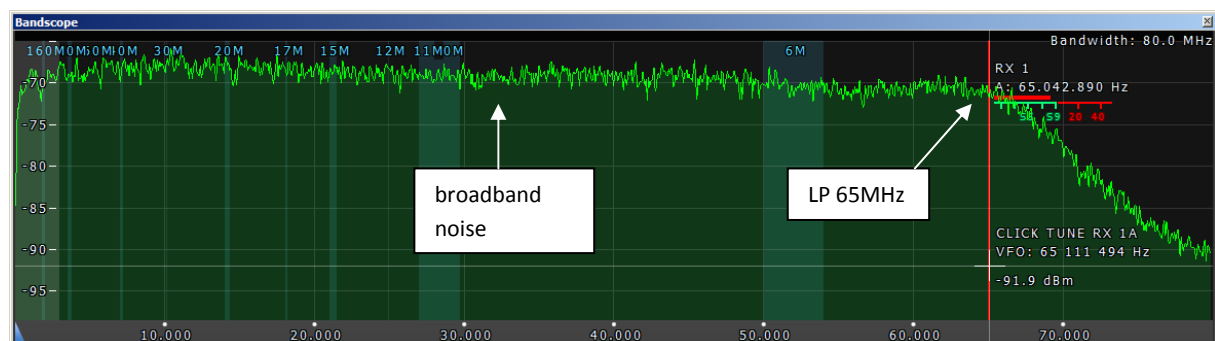

Figure 15: Spectrum with bandscope and Wide RX Filter on

The bandscope is set to the maximum display range of 0 to 80MHz and I use a noise signal again as input signal. With activated RX filter, one sees the unfiltered, spectral course of the noise, as an almost straight line, which drops at the limit frequency of the LP filter. When I turn off the RX filter and align the receiver to e.g. 14.2MHz, the receiver automatically activates a bandpass filter suitable for this frequency range, here in the 20m band, and the noise signal is greatly attenuated outside the filter passband **(Figure 16)**.

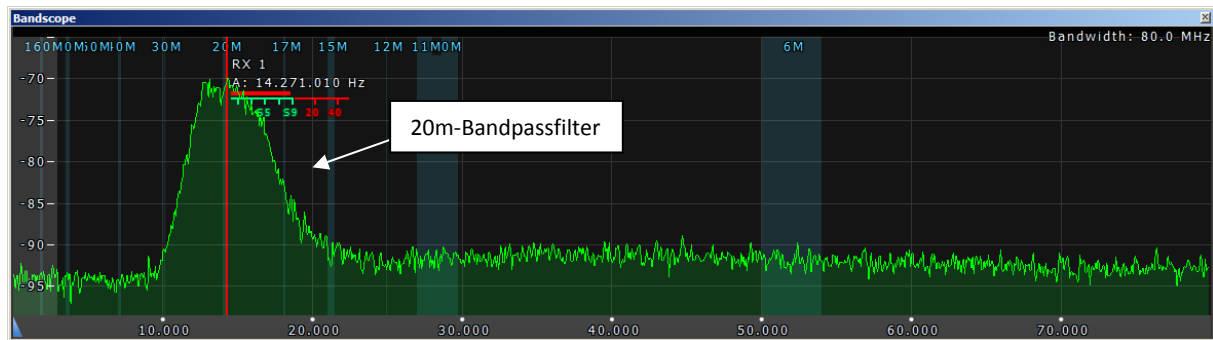

Figure 16: Spectrum with Wide RX filter off. The receiver now automatically selects a suitable, selective BP filter, in the example at 14.2 MHz in the 20 m band.

Conclusion: Both settings are possible when receiving signals. With the help of Bandscope and Wide RX-Filter on, one can check what kind of signals and levels from 0-65MHz are present at the input of the receiver. Since the sum of all signals from my antenna is mostly not more than -40dBm I usually use the 65MHz LP-Filter. However, if you want to be safe from overload, you should disable the Wide RX filter.

Spurious Signals

The bandscope can also be used to detect the unwanted interference signals (birdies) of the receiver. To do this, terminate the receiver's input at 50 ohms and set the bandscope to the maximum display range of 0-80MHz (**Figure 17**). Then you see the Spurious Signals of the receiver. In the example, there are at least four signals (20, 40, 60MHz, 80MHz), with levels around -100dBm.



Bild 17: Receiver Spurious Signals from 0-80MHz

Measurements on the transmitter

RF output power

Connect the RF output of the transceiver to a spectrum analyzer via a 40dB attenuator. Connect microphone input to an audio generator and set to 700Hz. Increase the NF amplitude until the transmitter gives its maximum power (P_0). If "Enable MIC AGC" is selected, the transmitter cannot be overdriven when the microphone level is increased.

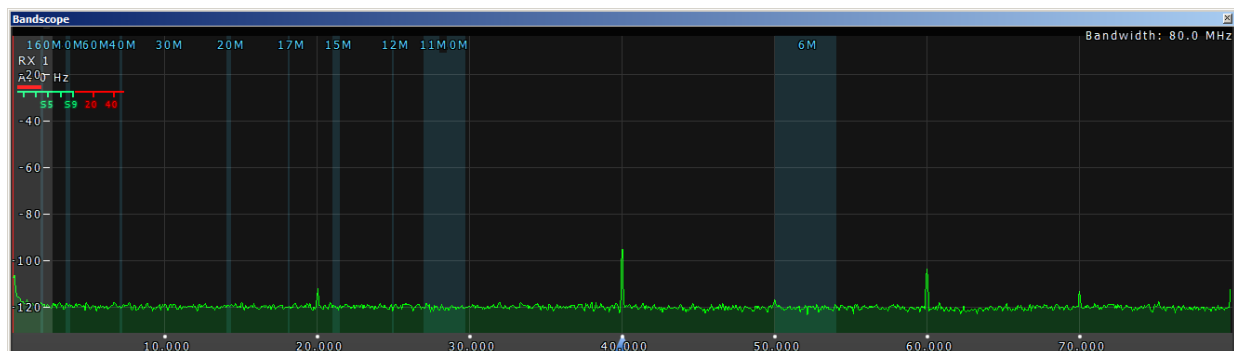
Settings: Test frequencies 3.6, 14.2, 28.3 and 145MHz, NF signal 700Hz, Drive 100%, Enable Mic AGC on, LSB / USB, supply 15VDC

| | P_0 , Watt |
|----------|--------------|
| 3,6 MHz | 21,5 |
| 14,1 MHz | 19,5 |
| 28,3 MHz | 20,0 |
| 145 MHz | 8,0 |

Table 7: Maximum RF output power, depending on the frequency

2-tone IMD3 test

In this test, an audio 2-tone signal (700Hz, 1500Hz) is fed into the microphone input of the SunSDR2Pro and the transmitter is adjusted to max. output power (**11**). In addition to the two signals (f_1 , f_2) the spectrum at the RF output also shows the unwanted intermodulation products, with the IMD3 generally having the highest amplitude. The suppression of the IMD3 products should be at least ≥ 25 dBc and the higher order IMD products should fall off relatively quickly. **Table 8** and **Figure 19-22** shows the resulting intermodulation in the 80, 20, 10 and 2m bands.

Settings: Testfrequenzen 3,6 , 14,2 , 28,3 und 145MHz, NF 2-Ton Signal 700Hz und 1500Hz mit gleichen Amplituden, LSB/USB, Drive 100%, Enable Mic AGC on

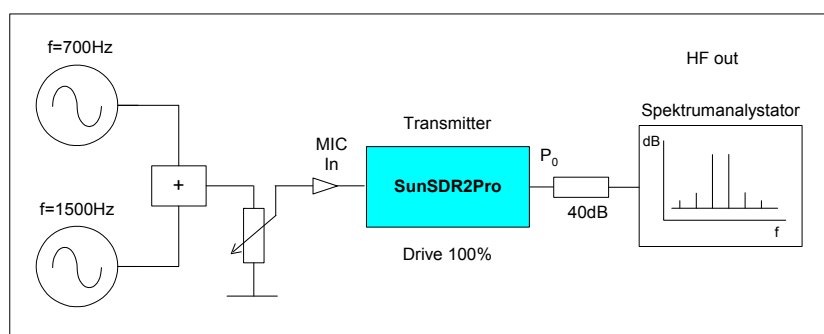

Figure 18: Transmitter IMD3 measurement

NF 2-tone generator

| f_1+f_2 | 3,6 MHz | 14,1 MHz | 28,3 MHz | 145MHz |
|-----------|---------|----------|----------|--------|
| IMD3 | 36 dBc | 37 dBc | 33 dBc | 30 dBc |
| IMD5 | 40 dBc | 50 dBc | 38 dBc | 47 dBc |
| IMD7 | 46 dBc | 52 dBc | 45 dBc | 60 dBc |
| IMD9 | 60 dBc | 56 dBc | 50 dBc | 64 dBc |

Tabelle 8: 2-Ton TX IMD

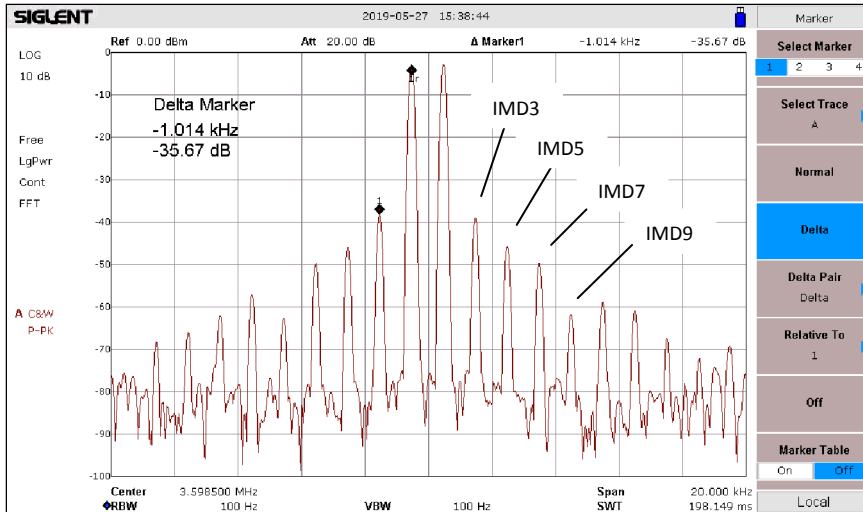

Fig 19: $f=3,6\text{MHz}$, 20Watt PEP, $\text{IMD3}=35,7\text{dBc}$

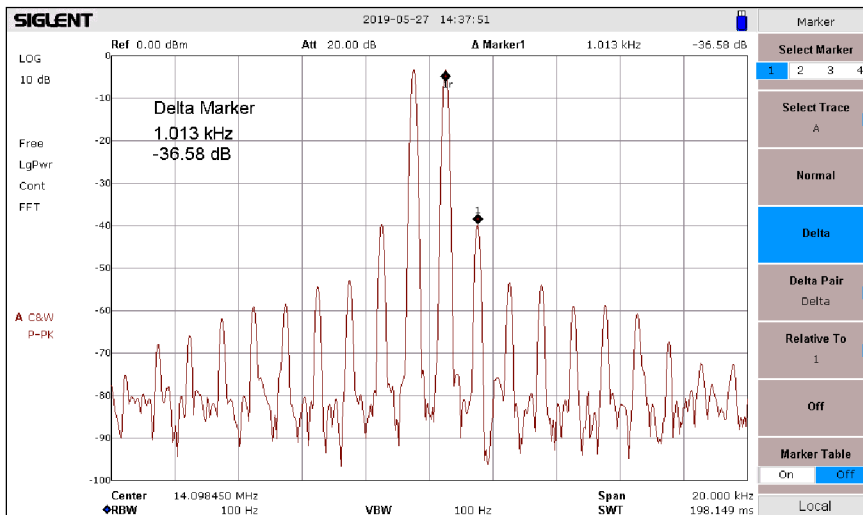

Fig 20: $f=14,1\text{MHz}$, 18.7Watt PEP, Delta $\text{IMD3} = 36,6\text{dBc}$

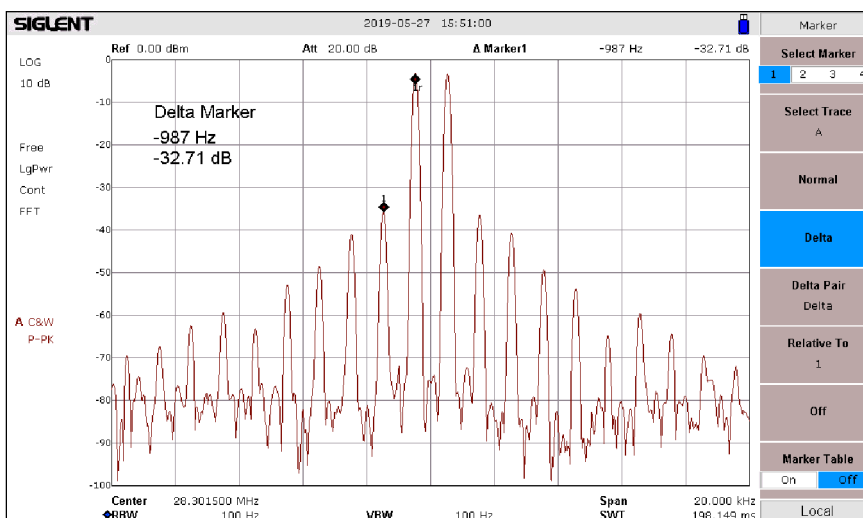

Fig 21: $f= 28.3\text{MHz}$, 18Watt PEP, Delta $\text{IMD3} = 32,7\text{dBc}$

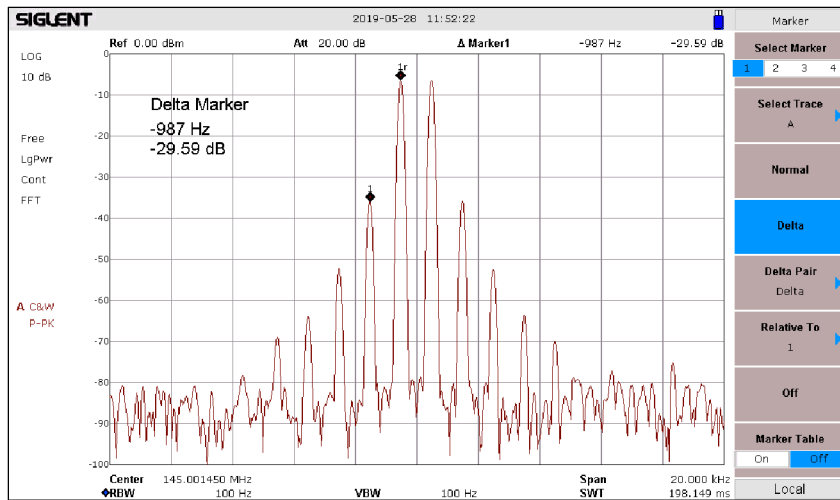

Fig 22: f=145MHz, 7.7Watt PEP, Delta IMD3 = 29,6dB

Harmonic suppression

Adjust the transmitter in the 80, 20, 10 and 2m band to maximum RF output power and measure the 2nd harmonic suppression (2xf) with a spectrum analyzer.

Settings: Testfrequenzen 3,6 , 14,2, 28,3 und 145MHz, NF 1-Ton Signal 700Hz, Drive 100%, Enable Mic AGC on, LSB/USB

| f | 2xf, Dämpfung (dB) der 1. Oberwelle |
|----------|-------------------------------------|
| 3,6 MHz | 72dBc bei 7,2MHz |
| 14,1 MHz | 71dBc bei 28,2MHz |
| 28,3 MHz | 72dBc bei 56,6MHz |
| 145 MHz | 62dBc bei 290MHz |

Table 9: Suppression of the 2nd harmonic

Control of transmission signal

As soon as the transmitter is switched on, the display shows the spectrum of the currently transmitted rf-signal, displayed over a bandwidth of 3 kHz (Fig. 23). So you can watch and control your own signal "live" at any time and see, weather your microphone is good or not.

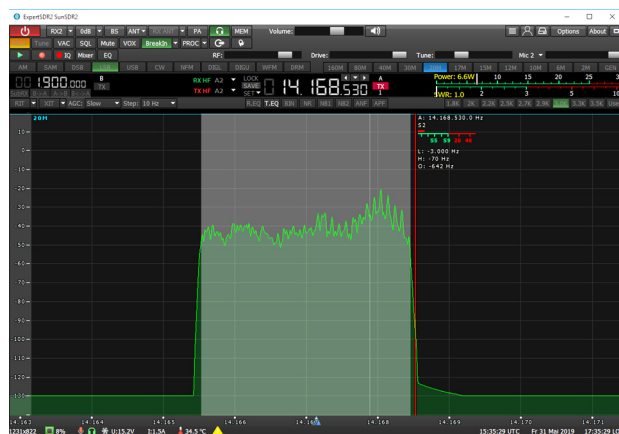

Figure 23: Screen shows the spectrum of the transmission signal

RF characteristics of the transceiver

117



2 kHz Reciprocal Mixing Dynamic Range (dB)

137



2 kHz Phase Noise (-dBm/Hz)

>120



2 kHz Blocking Gain Compression (dB)

84 87 93 (*)

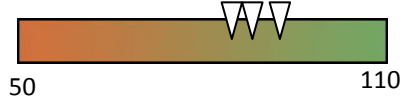

2 kHz 3rd-Order IMD Dynamic Range (dB)

109



2nd-Order IMD Dynamic Range (dB)

73



NPR Dynamic Range (dB)

-33 -36 (**)



Transmitter IMD3 (dB)

-50 -60 (**)

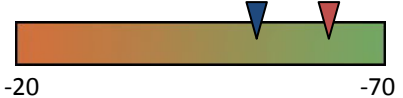

Transmitter IMD9 (dB)

(*) related to 14MHz residential noise level
 93dB with Gain off and WBF on
 87dB with Gain on and WBF on
 84dB with Gain on and WBF off
 (**) 3,6MHz ▼ 28,3MHz ▼

Tipps:

Reset Settings

Sometimes it may be necessary to reset the transceiver to its original IP address and ports. To do this, turn off the transceiver, press and hold the RST button on the back, and then turn the transceiver again on. The LED will then flash red / green and then release the RST button. After some time, the LED will be solid green. After the reset, the transceiver again has its IP address 192.168.16.200 and ports 50001, 50002.

Reinstall firmware

To reinstall the firmware, turn off the transceiver, press and hold the L / W key and turn the transceiver back on. The LED then flashes in green. Open the software ExpertSDR2 -> Options -> Device -> Select Firmware Update. After the firmware has been installed, the LED is solid green and the firmware installation is complete.

Temperature

The transceiver can get pretty hot, after 30 minutes in standby mode (15V, 0.9A) even up to +45 ° C. That's why I put a small, completely silent radial fan on the heat sink. After that the temperature stays below +35 ° C.



SunSDR2Pro with fan

Literatur

(1) Messung des Seitenbandrauschens von Empfängern und Oszillatoren

http://dc4ku.darc.de/Messung_Seitenbandrauschen.pdf

(2) Receiver Blocking Dynamic Range

http://www.dc4ku.darc.de/Receiver_Blocking_Dynamic_Range.pdf

(3) IM3-Festigkeit eines 2-Ton Generators

http://www.dc4ku.darc.de/IM3_Festigkeit_eines_HF_2_Tongenerators.pdf

(4) Radio Noise

<https://www.itu.int/rec/R-REC-P.372/en>

(5) Antennenrauschen im Kurzwellenbereich

http://www.dc4ku.darc.de/Antennenrauschen_im_Kurzwellenbereich.pdf

(6) Using Dither

<https://www.analog.com/media/en/training-seminars/tutorials/MT-004.pdf>

(7) Noise Power Ratio Testing of HF Receiver, Adam Farson

http://www.ab4oj.com/test/docs/npr_test.pdf

(8) Theoretical maximum NPR of a 16-bit ADC, Adam Farson

http://www.ab4oj.com/test/docs/16bit_npr.pdf

(9) Noise Power Ratio

http://www.dc4ku.darc.de/Noise_Power_Ratio.pdf

(10) ColibriNANO-Test

http://www.dc4ku.darc.de/ColibriNANO_Test.pdf

(11) NF-Doppelton-Generator mit Wien-Robinson-Brücke

http://www.dc4ku.darc.de/NF_Doppeltongenerator_mit_Wien_Robinson_Bruecke.pdf

Werner Schnorrenberg

DC4KU

07.06.2019