

DCP5.5x2.5UL246822+1.9M-RH:5.5*2.5MM DC PLUG TO OPEN. BLACK COLOR.

PART	MOLD NO	REV NO	DATE	REVISION NOTE
DC PLUG	CTD004			

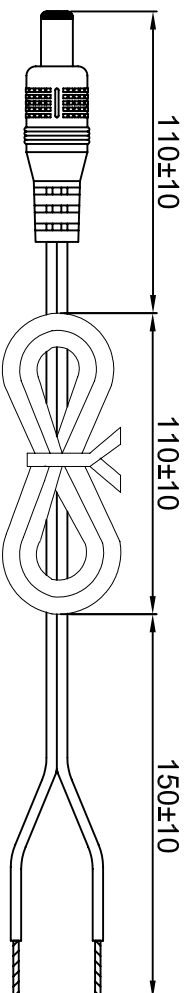
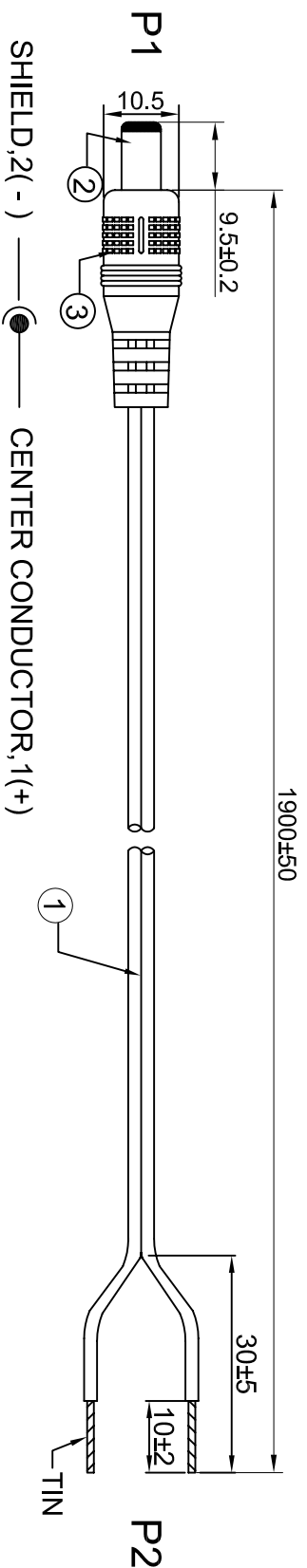

WIRE ADDRESS

P1 RED P2
 1 (+) OPEN
 2 (-) BLACK OPEN

CABLE CONSTRUCTION

ITEM	MATERIAL	SPEC
CENTER CONDUCTOR	TIN COPPER	
MATERIAL CONSTRUCT	mm/NO	0.16*17
MATERIAL	PVC/2F	
O.D.	mm	1.8*3.6±0.1
PVC JACKET COLOR	BLACK	

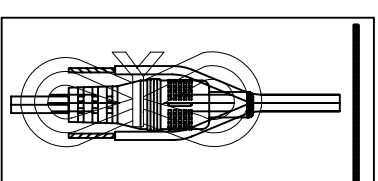

1PCS/PE BAG

PACKAGE

ELECTRICAL TEST

- 1) 100% OPEN SHORT&MISS WIRE TEST
- 2) INSULATION RESISTANCE: DC300V 50M OHM
- 3) CONDUCTOR RESISTANCE: 5 OHM

NO.	MATERIAL NO	PART NAME	MATERIAL/FINISH	QTY	UNIT
③	XXXXXXXXXXXX	OUTTER MOLD	45P PVC BLACK	3	G
②	XXXXXXXXXXXX	DC PLUG	5.5*2.5mm NICKEL PLATED	1	PCS
①	XXXXXXXXXXXX	CABLE	SEE" CABLE CONSTRUCTION"		MM

單位	MM	比例	1:1	圖法	圖數	1/1	文件編號	客戶	康力訊科技	日期	2009.02.09	版次	0.1	核准
單位	MM	比例	1:1	圖法	圖數	1/1	文件編號	客戶	康力訊科技	日期	2009.02.09	版次	0.1	核准
Connexions Technology Corp 康力訊科技股份有限公司 產品料號: DCP5.5x2.5UL246822 產品料號: +1.9M-RH 製圖: 曜磊 審核: 審核 Lucky														

STANDARD TOLERANCE LIMITS	UNLESS OTHER SPECIFIED
PANGE	TOLERANCE
>0-6	±0.08 ±0.14
>6-30	±0.10 ±0.20
>30-120	±0.20 ±0.30
>120-300	±0.30 ±0.40
>300-500	±0.40 ±0.50

MINI DIN 8PIN PLUG TO MINI DIN 8PIN PLUG, NICKEL PLATED

PART	MOLD NO	REV NO	DATE	REVISION NOTE
DC PLUG	CTD004			
MINI DIN 4PIN PLUG	CTP008/011			

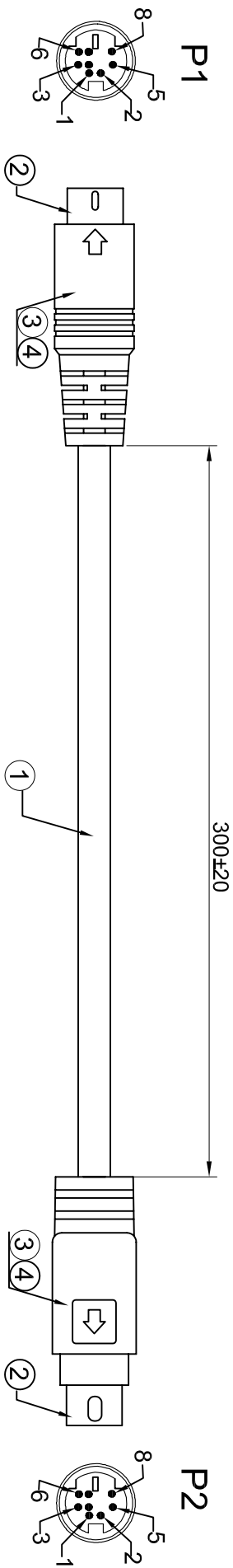

WIRE ADDRESS

P1	P2
1	1
2	2
3	3
4	4
5	5
6	6
7	7
8	8
S	S

CABLE CONSTRUCTION

ITEM	SPEC
CENTER CONDUCTOR	MATERIAL: CCA CONSTRUCT: 0.12*7 O.D.: mm
INSULATION	MATERIAL: PVC THICK: mm O.D.: 0.84
FOIL	MATERIAL: FOIL
DRAIN WIRE	MATERIAL: CCA CONSTRUCT: mm/No. 0.16*7
PVC JACKET	MATERIAL: PVC O.D.: mm 5.0±0.10 COLOR: BLACK

ELECTRICAL TEST

- 1) 100% OPEN SHORT & MISS WIRE TEST
- 2) INSULATION RESISTANCE: DC300V 50M OHM
- 3) CONDUCTOR RESISTANCE: 5 OHM

PACKAGE

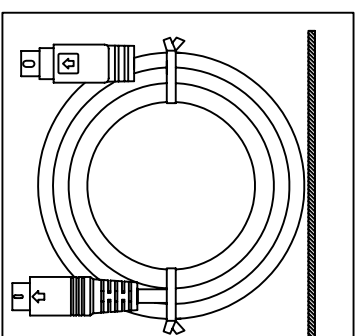

④	XXXXXXXXXXXX	OUTTER MOLD	45P PVC :PANONE #9162	2	G
③	XXXXXXXXXXXX	INNER MOLD	PE TRANSPARENT	1	PCS
②	XXXXXXXXXXXX	MINI DIN 8PIN PLUG	MINI DIN8P NICKEL PLATED	2	PCS
①	XXXXXXXXXXXX	CABLE	SEE" CABLE CONSTRUCTION"		MM
NO.	MATERIAL NO	PART NAME	MATERIAL/FINISH	Q'TY	UNIT

單位	MM	比例	1:1	文件編號	客戶	產品料號	CM08MM08M280 800710NM-4K-RH	制圖	審核	Billow
圖法	比例	頁數	1/1	發行日期	2009.02.09	版次	0.1	核准		
STANDARD TOLERANCE LIMITS UNLESS OTHER SPECIFIED RANGE TOLERANCE >0-6 ±0.08 ±0.14 >6-30 ±0.10 ±0.20 >30-120 ±0.20 ±0.30 >120-300 ±0.30 ±0.40 >300-500 ±0.40 ±0.50										

Connexions Technology Corp
康力訊科技股份有限公司

IC-PAC CABLE(5030HMA4P-DCP5.5x2.5+35.6CM):356MM,4P HOUSING MALE TO 3.5STEREO PLUG+5.5*2.5MM DC PLUG,NICKEL PLATED.

PART	MOLD NO	REV NO	DATE	REVISION NOTE
DC PLUG	CTD004	△1	09.04.08	變更模具號碼
3.5 PLUG	CT3002	△2	11.04.14	增加接線PCB
SR	CTS021	△3	18.10.06	修正尺寸標注

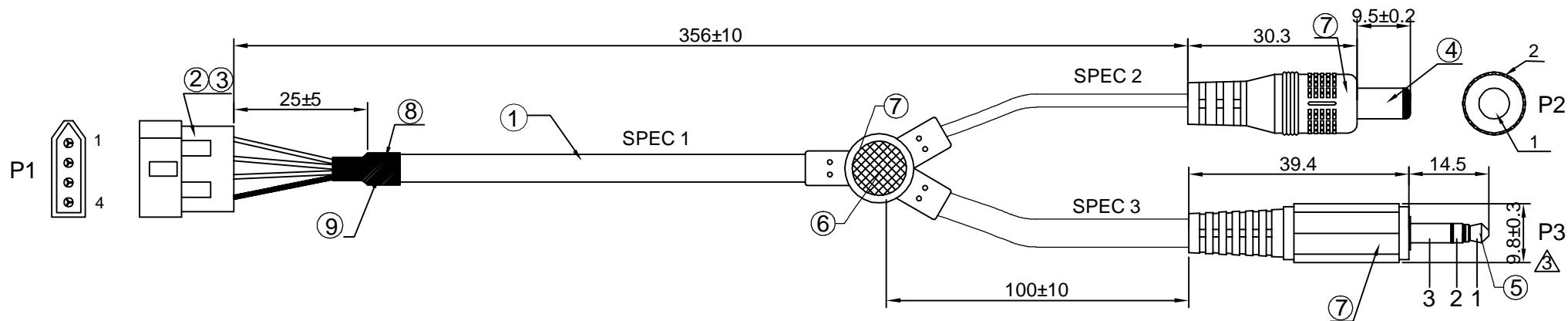

WIRE ADDRESS

P1	P2	P3
1	RED	1
2	WHITE	2
3	BLACK 1	3
4	SPIRAL 2	SPIRAL 3

CABLE CONSTRUCTION

ITEM		SPEC 1	SPEC 2	SPEC 3
CENTER CONDUCTOR	MATERIAL	CCA	CCA	CCA
	CONSTRUCT mm/NO.	0.18*21	0.18*21	0.18*21
INSULATION	MATERIAL	PVC	PVC	PVC
	O.D. mm	1.75±0.05/3C	1.75±0.05/1C	1.75±0.05/2C
SHIELD	MATERIAL	CCA	CCA	CCA
	CONSTRUCT mm/NO.	0.18*21	0.12*45	0.12*52
FOIL	MATERIAL	AL/MY	/	/
PVC JACKET	MATERIAL	PVC	PVC	PVC
	O.D. mm	4.7±0.1	3.0±0.1	4.7±0.1
	COLOR	GREY	GREY	GREY

PACKAGING

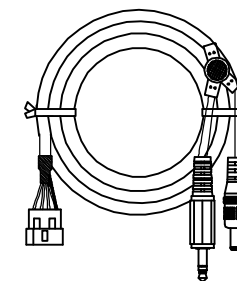

500PCS/CARTON

⑨	XXXXXXXXXX	SHIRNK TUBE	OD:0.8MM BLACK L=30MM	1	PCS
⑧	XXXXXXXXXX	SHIRNK TUBE	OD:5.0MM BLACK L=15MM	1	PCS
⑦	XXXXXXXXXX	OUTER MOLD	45P PVC COLOR:GRAY	12	G
⑥	XXXXXXXXXX	PCB	6.5*8*1.0mm PCB	1	PCS
⑤	XXXXXXXXXX	3.5 ST PLUG	3.5MM STEREO NICKEL PLATED	1	PCS
④	XXXXXXXXXX	DC PLUG	5.5*2.5*21.5mm NICKEL PLATED	1	PCS
③	XXXXXXXXXX	TERMINAL	PH:5.03MM,MALE,TIN PLATED	4	PCS
②	XXXXXXXXXX	HOUSING	PH:5.03MM, 1*4P HOUSING,WHITE	1	PCS
①	XXXXXXXXXX	CABLE	SEE" CABLE CONSTRUCTION"		MM
NO.	MATERIAL NO	PART NAME	MATERIAL/FINISH	Q'TY	UNIT

ELECTRICAL TEST

- 1)100% OPEN SHORT&MISS WIRE TEST
- 2)INSULATION RESISTANCE:DC300V 50M OHM
- 3)CONDUCTOR RESISTANCE:5 OHM

單位	MM	比例	1:1				
圖法	☉	頁數	1/1	客戶	A608	制圖	chenjun
文件編號				產品料號	IC-PAC CABLE	審核	
料號				發行日期	2018.10.24	版次	1.3
						核准	

STANDARD TOLERANCE LIMITS UNLESS OTHER SPECIFIED		
RANGE	TOLERANCE	
>0-6	±0.08	±0.14
>6-30	±0.10	±0.20
>30-120	±0.20	±0.30
>120-300	±0.30	±0.40
>300-600	±0.40	±0.50

0.3M 3.5 STEREO PLUG TO 3.5 STEREO PLUG CABLE, NICKEL PLATED, BLACK COLOR, MOLDING TYPE

PART	MOLD NO
OUTER MOLD	CT3002

Rev NO	Date	Revision note
Δ		
Δ		
Δ		

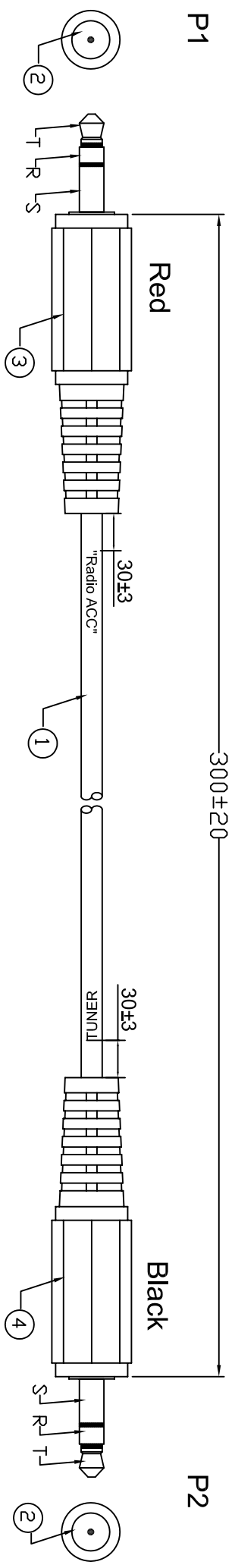

CABLE CONSTRUCTION

ITEM	MATERIAL	SPEC
CENTER CONDUCTOR	CONSTRUCT	CCA
	mm/NO.	0.167
INSULATION	MATERIAL	PVC
	ID.	1.04±0.05/2C
GROUNDING	MATERIAL	CCA
	CONSTRUCT	mm/NO.
	MATERIAL	PVC
	O.D.	MM
	COLOR	BLACK

ELECTRICAL TEST

- 1) 100% OPEN SHORT & MISS WIRE TEST
- 2) INSULATION RESISTANCE: DC500V 10MΩ
- 3) CONDUCTOR RESISTANCE: 3 OHM

PACKING

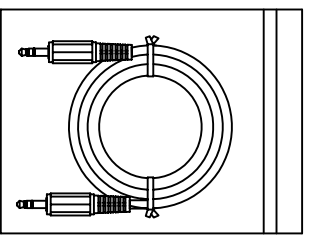

1PCS/POLYBAG

WIRE ADDRESS

P1 Shield P2 Shield

Ring Tip

Tip NIC Ring NIC

NO.	MATERIAL ND	MATERIAL	SPEC	Q 'TY	UNIT
4	XXXXXXXXXXXXXXXXXX	45P PVC BLACK COLOR		0.007	KG
3	XXXXXXXXXXXXXXXXXX	45P PVC RED COLOR		0.007	KG
2	XXXXXXXXXXXXXXXXXX	3.5 STEREO PLUG, NICKEL PLATED		2	PCS
1	XXXXXXXXXXXXXXXXXX	SEE "CABLE CONSTRUCTION"			

STANDARD TOLERANCE LIMITS		單位	MM	比例	1/1	Connexions Technology Corp	
UNLESS OTHER SPECIFIED		圖法	☐	實數		康力訊科技股份有限公司	
PANGE	TOLERANCE	文件編號				客戶	曜磊
>0-6	±0.08 ±0.14	圖號				產品	3.5 STEREO
>6-30	±0.10 ±0.20	圖號				料號	PLUG2-30CM/PWED
>30-120	±0.20 ±0.30	圖號				料號	
>120-300	±0.30 ±0.40	圖號				料號	
>300-600	±0.40 ±0.50	圖號				料號	
		日期				版次	0.1
							核准

Y-ACC-2, 3FT DIN10P MALE TO 3.5 STEREO PLUG ,NICKEL PLATED.

PART	MOLD NO	REV NO	DATE	REVISION NOTE
3.5 PLUG	CT3002			
DIN10P	CTP069/070			

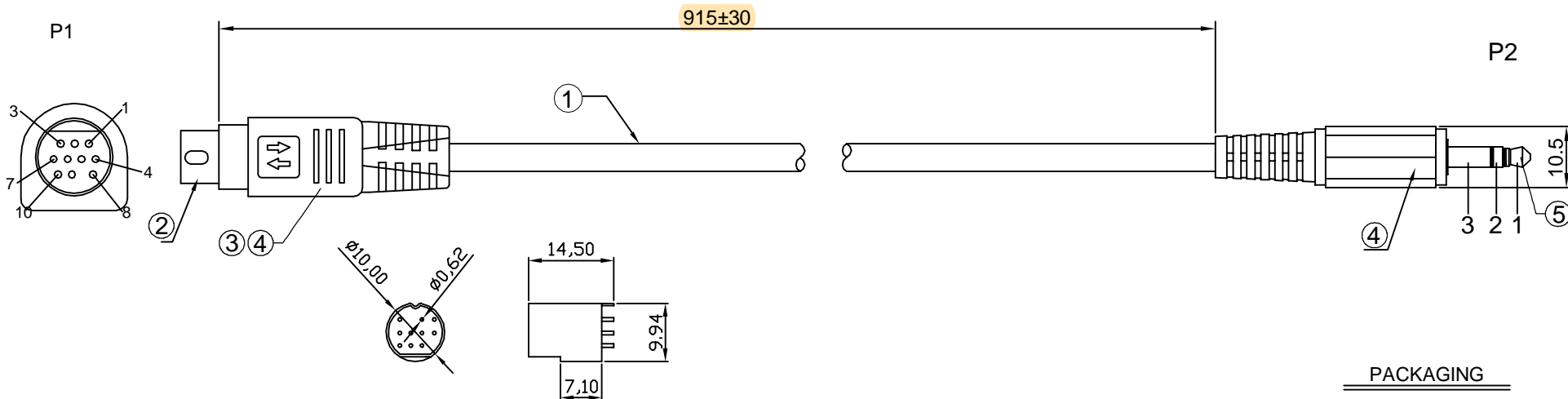

WIRE ADDRESS

P1		P2
10	RED	1
3	BLACK	3

CABLE CONSTRUCTION

ITEM	SPEC 1
CENTER CONDUCTOR	MATERIAL CCA
	CONSTRUCT mm/NO. 0.18*21
INSULATION	MATERIAL PVC
	O.D. mm 1.75±0.05/2C
FOIL	MATERIAL AL/MY
PVC JACKET	MATERIAL PVC
	O.D. mm 4.7±0.1
	COLOR GREY

PACKAGING

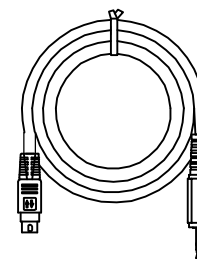

500PCS/CARTON

ELECTRICAL TEST

- 1)100% OPEN SHORT&MISS WIRE TEST
- 2)INSULATION RESISTANCE:DC300V 50M OHM
- 3)CONDUCTOR RESISTANCE:5 OHM

⑤	XXXXXXXXXX	3.5 ST PLUG	3.5MM STEREO NICKEL PLATED	1	PCS
④	XXXXXXXXXX	OUTER MOLD	45P PVC COLOR:GRAY	9	G
③	XXXXXXXXXX	INNER MOLD	PE TRANSPARENT	4	G
②	XXXXXXXXXX	DIN PLUG	DIN 10PIN PLUG,NICKEL PLATED,	1	PCS
①	XXXXXXXXXX	CABLE	SEE" CABLE CONSTRUCTION"		MM
NO.	MATERIAL NO	PART NAME	MATERIAL/FINISH	Q'TY	UNIT

STANDARD TOLERANCE LIMITS UNLESS OTHER SPECIFIED		
PANGE	TOLERANCE	
>0-6	±0.08	±0.14
>6-30	±0.10	±0.20
>30-120	±0.20	±0.30
>120-300	±0.30	±0.40
>300-600	±0.40	±0.50

單位	MM	比例	1:1				
圖法	第一角	頁數	1/1				
文件編號		客戶	A608	制圖	XIAO		
康力調料號		產品料號	Y-ACC-2	審核			
發行日期	2021.11.01	版次	0.1	核准			

Y-ACC-3, 3FT DB15P MALE TO 3.5 STEREO PLUG ,NICKEL PLATED.

PART	MOLD NO	REV NO	DATE	REVISION NOTE
3.5 PLUG	CT3002			
DP15PIN PLUG	CTS028			

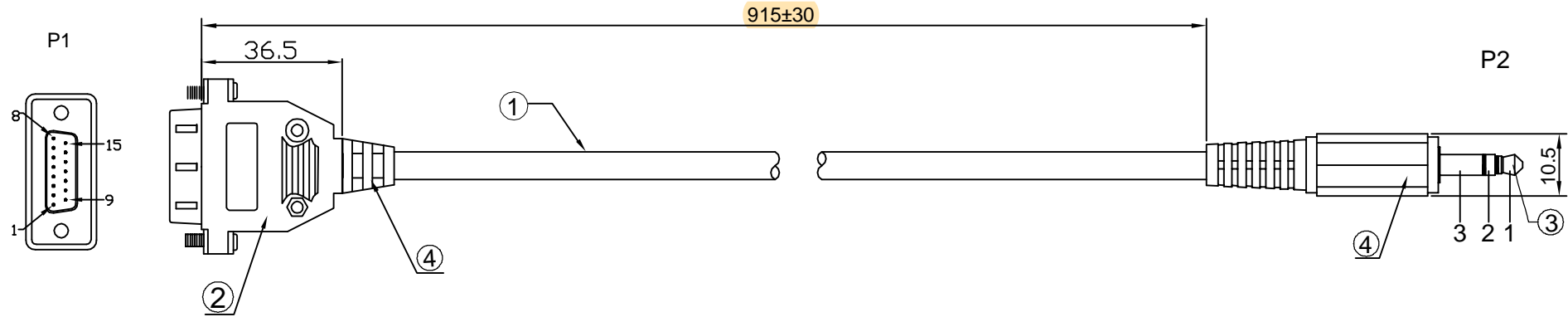

WIRE ADDRESS

P1		P2
11	RED	1
3	BLACK	3

CABLE CONSTRUCTION

ITEM		SPEC 1
CENTER CONDUCTOR	MATERIAL	CCA
	CONSTRUCT	mm/NO. 0.18*21
INSULATION	MATERIAL	PVC
	O.D.	mm 1.75±0.05/2C
FOIL	MATERIAL	AL/MY
	MATERIAL	PVC
PVC JACKET	O.D.	mm 4.7±0.1
	COLOR	GREY

PACKAGING

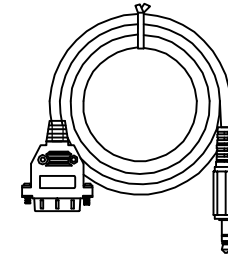

500PCS/CARTON

ELECTRICAL TEST

- 1)100% OPEN SHORT&MISS WIRE TEST
- 2)INSULATION RESISTANCE:DC300V 50M OHM
- 3)CONDUCTOR RESISTANCE:5 OHM

④	XXXXXXXXXX	OUTER MOLD	45P PVC COLOR:GRAY	9	G
③	XXXXXXXXXX	3.5 ST PLUG	3.5MM STEREO NICKEL PLATED	1	PCS
②	XXXXXXXXXX	DB 15PIN PLUG	DB 15PIN PLUG,NICKEL PLATED,	1	SET
①	XXXXXXXXXX	CABLE	SEE" CABLE CONSTRUCTION"		MM
NO.	MATERIAL NO	PART NAME	MATERIAL/FINISH	Q'TY	UNIT

單位	MM	比例	1:1				
圖法	☉	頁數	1/1				
文件編號				客戶	A608	制圖	XIAO
康力訊料號				產品料號	Y-ACC-3	審核	
發行日期	2021.11.01			版次	0.1	核准	

STANDARD TOLERANCE LIMITS UNLESS OTHER SPECIFIED		
RANGE	TOLERANCE	
>0-6	±0.08	±0.14
>6-30	±0.10	±0.20
>30-120	±0.20	±0.30
>120-300	±0.30	±0.40
>300-600	±0.40	±0.50